

Organic chemistry

1. Which reaction of ethene is **not** an addition reaction?

- A reaction with bromine
- B reaction with hydrogen
- C reaction with oxygen
- D reaction with steam

2. Ethanol is a fuel used in cars. It can be made from petroleum.

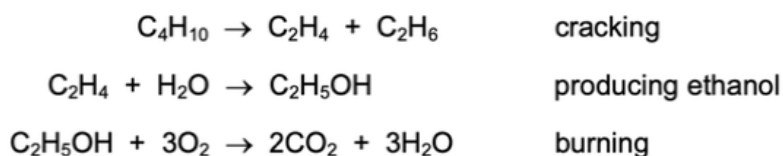

Compounds of how many homologous series appear in these equations?

- A 1 B 2 C 3 D 4

3. Ethanol is produced from either ethene or sugar.

Which type of chemical reaction is used in each case?

	ethene → ethanol	sugar → ethanol
A	addition	fermentation
B	addition	fractional distillation
C	distillation	fermentation
D	distillation	fractional distillation

4. The structural formula of an organic compound is shown.



What is the name of this compound?

- A butanoic acid
- B ethyl ethanoate
- C methyl propanoate
- D propyl methanoate

5. The diagram shows the structure of an important product.

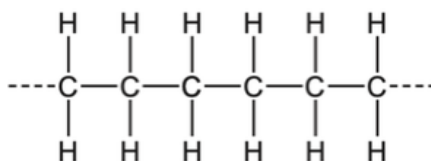

This product is formed by 1 of an 2

Which words complete gaps 1 and 2?

	1	2
A	addition polymerisation	alkane
B	addition polymerisation	alkene
C	cracking	alkane
D	cracking	alkene

6. Which pair of compounds reacts to form a condensation polymer?

- A** CH_3COOH and $\text{C}_2\text{H}_5\text{NH}_2$
- B** HCOOH and $\text{HOC}_2\text{H}_4\text{OH}$
- C** $\text{HOC}_6\text{H}_{12}\text{OH}$ and $\text{HOOC}_3\text{H}_6\text{COOH}$
- D** $\text{H}_2\text{NC}_2\text{H}_4\text{NH}_2$ and $\text{HOC}_3\text{H}_6\text{OH}$

7. Which fraction of petroleum is **not** matched to its correct use?

	fraction	use
A	bitumen	making roads
B	gasoline	fuel for cars
C	kerosene	fuel for ships
D	naphtha	chemical industry

8. The diagram shows the structures of two organic molecules.

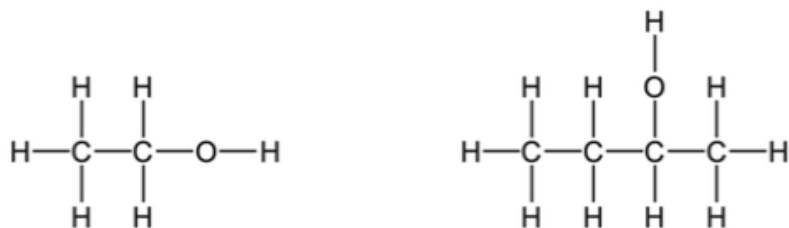

Which statement about these molecules is **not** correct?

- A They are both alcohols.
 - B They both produce carbon dioxide and water when they burn in oxygen.
 - C They contain different functional groups.
 - D They have the same general formula.
9. The diagram shows part of the molecule of a polymer.

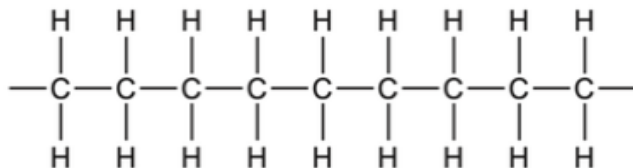

Which diagram shows the monomer from which this polymer could be manufactured?

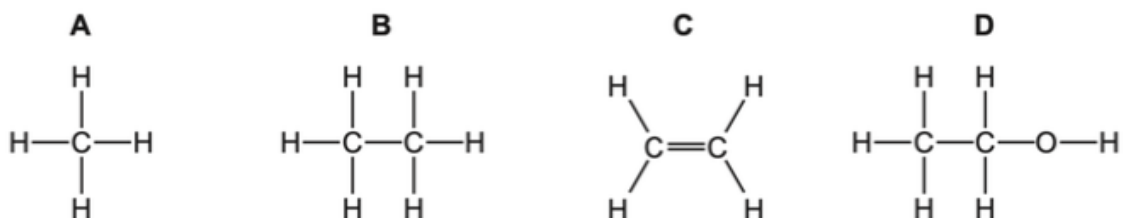

10. Ethanol is manufactured by fermentation or by the catalytic addition of steam to ethene.

Which statement is correct?

- A Fermentation uses a higher temperature than the catalytic addition of steam to ethene.
- B Fermentation uses a non-renewable resource.
- C The catalytic addition of steam to ethene produces purer ethanol than fermentation.
- D The catalytic addition of steam to ethene uses a biological catalyst.

11. The structure of an ester is shown.

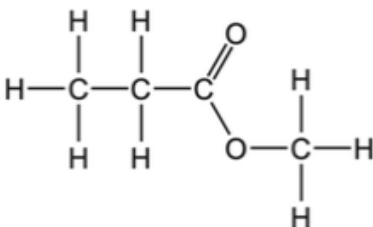

Which row is correct?

	name of ester	names of the carboxylic acid and the alcohol used to form the ester
A	methyl propanoate	methanoic acid and propanol
B	methyl propanoate	methanol and propanoic acid
C	propyl methanoate	methanoic acid and propanol
D	propyl methanoate	methanol and propanoic acid

12. Keratin is a protein that is found in human hair.

Keratin is chemically broken down to produce amino acids.

What is the name of this chemical process?

- A** catalysis
- B** hydration
- C** hydrolysis
- D** polymerisation

13. Which statement about homologous series is **not** correct?

- A** Alkenes have the same general formula, C_nH_{2n+2} .
- B** Each member of the homologous series of alkanes differs from the next by CH_2 .
- C** The members of a homologous series all have similar chemical properties.
- D** The members of a homologous series all have the same functional group.

14. The industrial fractional distillation of petroleum is shown.

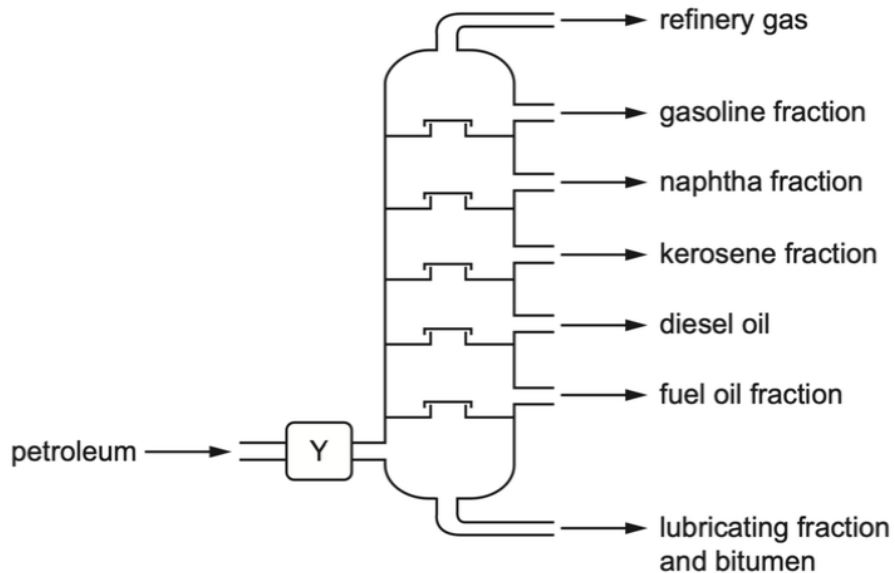

Which process happens at Y?

- A burning
- B condensation
- C cracking
- D evaporation

15. The diagram shows part of the molecule of a polymer.

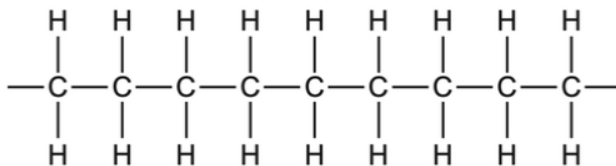

Which diagram shows the monomer from which this polymer could be manufactured?

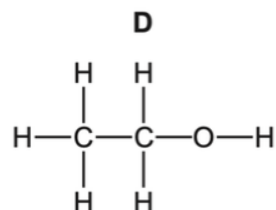
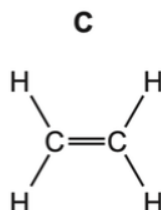
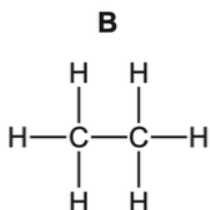
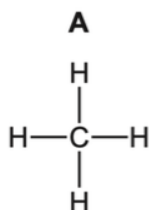

16. Ethanol is manufactured by fermentation or by the catalytic addition of steam to ethene.

What is an advantage of ethanol manufacture by fermentation instead of by the catalytic addition of steam to ethene?

- A Ethanol manufactured by fermentation is purified by distillation.
- B Ethanol manufacture by fermentation produces purer ethanol.
- C Ethanol manufacture by fermentation uses large areas of land.
- D Ethanol manufacture by fermentation uses renewable resources.

17. The formula of an ester is $\text{CH}_3\text{CH}_2\text{CH}_2\text{COOCH}_2\text{CH}_2\text{CH}_3$.

Which acid and alcohol react together to make the ester?

	acid	alcohol
A	butanoic acid	butanol
B	butanoic acid	propanol
C	propanoic acid	butanol
D	propanoic acid	propanol

18. Polyesters and polyamides are types of synthetic polymer.

Which statements are correct?

- 1 They are made by addition polymerisation.
- 2 They are made by condensation polymerisation.
- 3 The monomers from which they are made are unsaturated hydrocarbons.
- 4 The monomers from which they are made contain reactive functional groups at their ends.

- A** 1 and 3 **B** 1 and 4 **C** 2 and 3 **D** 2 and 4

19. Butane and methylpropane are isomers with molecular formula C_4H_{10} .

Which statements are correct?

- 1 They have similar chemical properties.
- 2 They have the same general formula.
- 3 They have the same structural formula.

- A** 1, 2 and 3 **B** 1 and 2 only **C** 1 and 3 only **D** 2 and 3 only

20. Fuel oil, gasoline, kerosene and naphtha are four fractions obtained from the fractional distillation of petroleum.

What is the order of the boiling points of these fractions?

	highest boiling point → lowest boiling point
A	fuel oil → kerosene → gasoline → naphtha
B	fuel oil → kerosene → naphtha → gasoline
C	gasoline → naphtha → kerosene → fuel oil
D	naphtha → gasoline → kerosene → fuel oil

21. Ethanol can be produced by fermentation or by the catalytic addition of steam to ethene.

Which row shows an advantage and a disadvantage for each process?

	fermentation		catalytic addition of steam to ethene	
	advantage	disadvantage	advantage	disadvantage
A	batch process	slow reaction	continuous process	fast reaction
B	fast reaction	continuous process	pure ethanol formed	renewable raw material
C	renewable raw material	batch process	pure ethanol formed	slow reaction
D	renewable raw material	impure ethanol formed	fast reaction	finite raw material

22. How can the amino acids in a protein be separated and identified?

- A** Add a locating agent to the protein.
- B** Hydrolyse the protein and then use chromatography.
- C** Polymerise the protein and then add a locating agent.
- D** Use chromatography on a solution of the protein.

23. The structures of some organic molecules are shown.

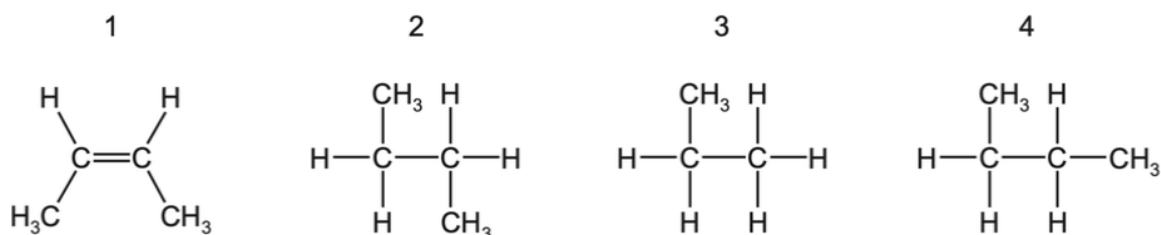

Which structures represent an alkane with four carbon atoms?

- A** 1 only **B** 2 and 3 **C** 2 and 4 **D** 3 and 4
24. Some of the fractions obtained from the fractional distillation of petroleum are used as fuels for vehicles.

Which two fractions are used as fuels for vehicles?

- A** bitumen fraction and gasoline fraction
B bitumen fraction and naphtha fraction
C gasoline fraction and kerosene fraction
D kerosene fraction and lubricating fraction

25. X, Y and Z are three hydrocarbons.

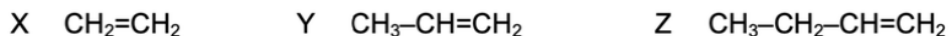

What do compounds X, Y and Z have in common?

- 1 They are all alkenes.
2 They are all part of the same homologous series.
3 They all have the same boiling point.

- A** 1, 2 and 3 **B** 1 and 2 only **C** 1 and 3 only **D** 2 and 3 only

26. Which pair of compounds can be used to prepare $\text{CH}_3\text{CH}_2\text{COOCH}_2\text{CH}_3$?

- A** ethanoic acid and ethanol
B ethanoic acid and propanol
C propanoic acid and ethanol
D propanoic acid and propanol

27. The diagram shows a reaction sequence.

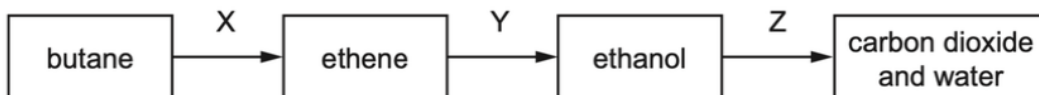

Which row names the processes X, Y and Z?

	X	Y	Z
A	cracking	fermentation	respiration
B	cracking	hydration	combustion
C	distillation	fermentation	respiration
D	distillation	hydration	combustion

28. The structure of a synthetic polymer is shown.

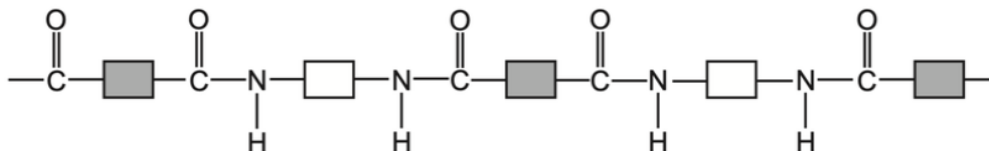

The structure shows that it is a1..... . It is formed by2..... polymerisation.

Which words complete gaps 1 and 2?

	1	2
A	polyamide	addition
B	polyamide	condensation
C	polyester	addition
D	polyester	condensation

29. Which statement is **not** correct?

- A** Petroleum is a mixture of hydrocarbons.
- B** The main constituent of natural gas is ethane.
- C** The naphtha fraction of petroleum is used for making chemicals.
- D** When natural gas burns in air, carbon dioxide and water are formed.

30. The structures of four organic compounds are shown.

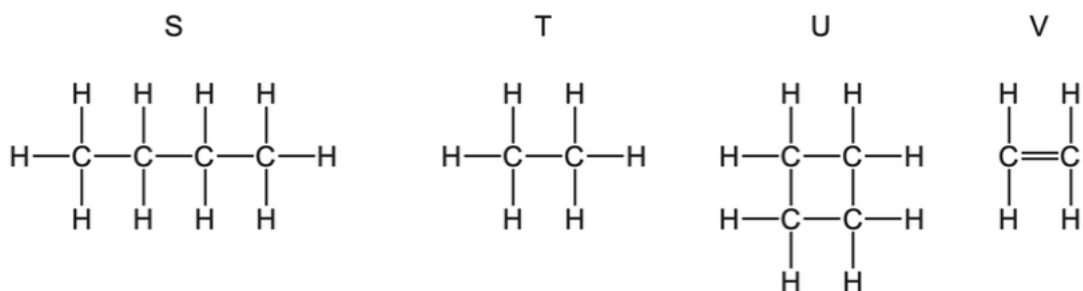

Which compounds are unsaturated?

- A** S only **B** T and U **C** U only **D** V only

31. X, Y and Z are three hydrocarbons.

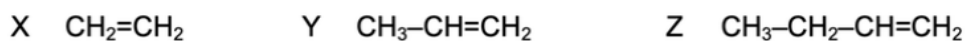

What do compounds X, Y and Z have in common?

- 1 They are all alkenes.
- 2 They are all part of the same homologous series.
- 3 They all have the same boiling point.

- A** 1, 2 and 3 **B** 1 and 2 only **C** 1 and 3 only **D** 2 and 3 only

32. The diagram shows a reaction sequence.



Which row names the processes X, Y and Z?

	X	Y	Z
A	cracking	fermentation	respiration
B	cracking	hydration	combustion
C	distillation	fermentation	respiration
D	distillation	hydration	combustion

33. The structure of an ester is shown.

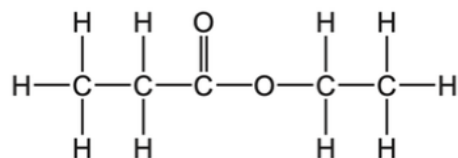

Which substances react to form this ester?

- A** ethanol and ethanoic acid
- B** ethanol and propanoic acid
- C** propanol and ethanoic acid
- D** propanol and propanoic acid

34. A polymer can be made from methyl propene.

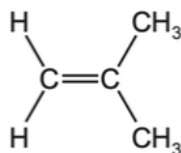

Which diagram shows the structure of the polymer?

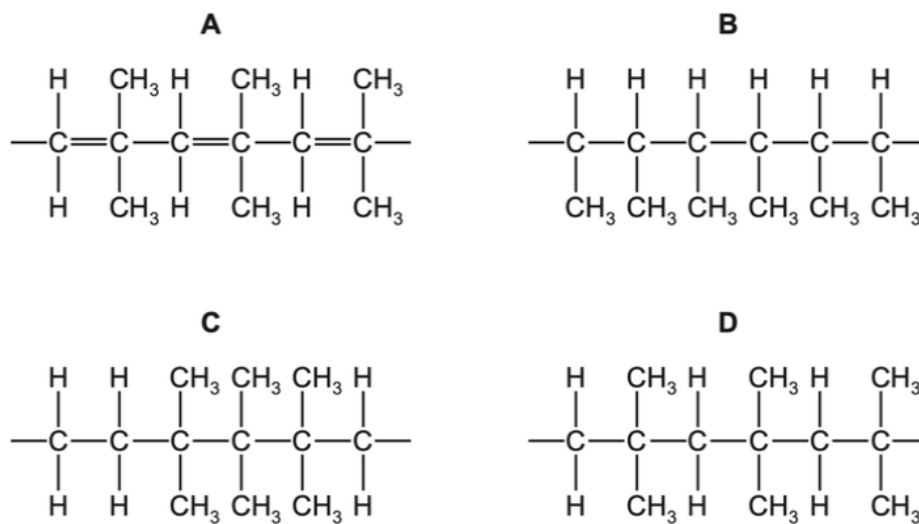

35. Fuel oil and naphtha are two fractions obtained from petroleum.

What are the major uses of these fractions?

	fuel oil	naphtha
A	jet fuel	making chemicals
B	jet fuel	making roads
C	ship fuel	making chemicals
D	ship fuel	making roads

36. The equation shows the formation of a polymer called *Kevlar*.

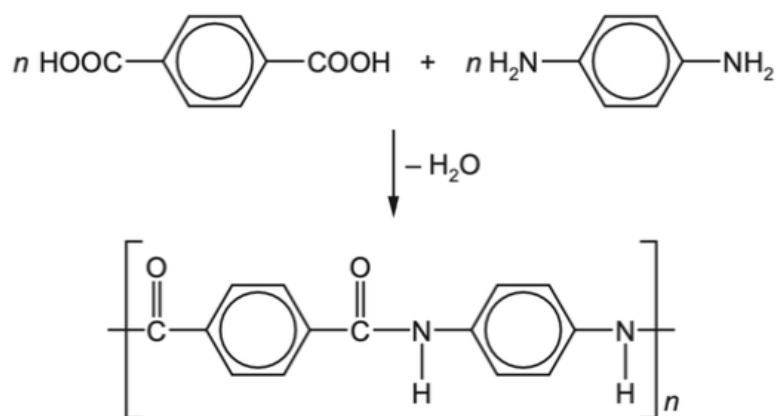

Which row describes *Kevlar*?

	how the polymer is formed	type of polymer
A	addition polymerisation	polyamide
B	addition polymerisation	polyester
C	condensation polymerisation	polyamide
D	condensation polymerisation	polyester

37. (a) Five organic compounds have the following structures.

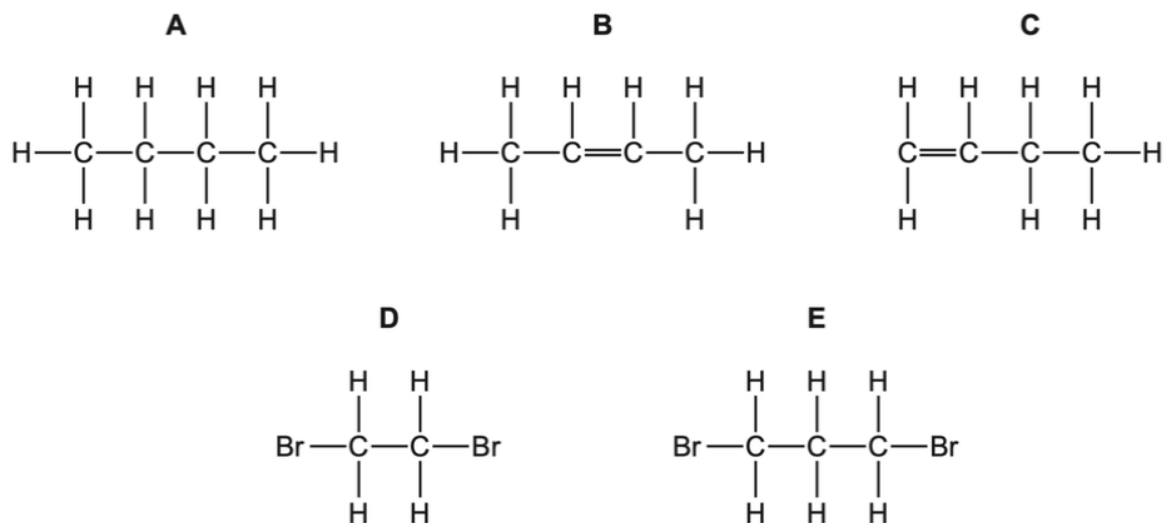

(i) Which compound is butane?

..... [1]

(ii) Which **two** compounds are structural isomers of each other?

..... [1]

(iii) Which compound can be made by reacting an alkene with bromine?

..... [1]

(iv) Which compound is a saturated hydrocarbon?

..... [1]

(v) Which compound has the empirical formula C_2H_5 ?

..... [1]

(vi) Name the **two** products made during the complete combustion of compound **C**.

..... [1]

(b) Petroleum can be separated into useful substances using the apparatus shown.

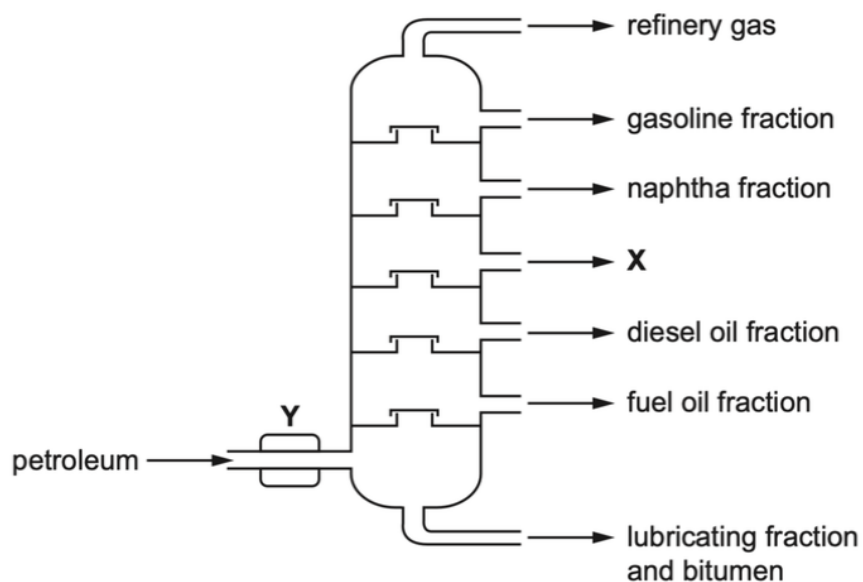

(i) Name the fraction which is the most viscous.

..... [1]

(ii) Name the fraction with the smallest molecules.

..... [1]

(iii) Name the fraction which has the weakest attractive forces between molecules.

..... [1]

(iv) Fraction **X** is used as jet fuel.

Name fraction **X**.

..... [1]

(v) What happens at point **Y** on the diagram?

..... [1]

38. (a) The diagram shows part of the structure of an addition polymer.

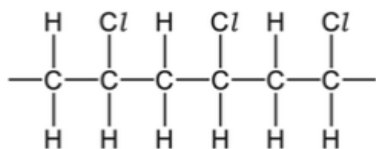

(i) Draw a circle around **one** repeat unit of the polymer. [1]

(ii) Draw the structure of the monomer from which this addition polymer is made.

[1]

(iii) Aqueous bromine is added to both the polymer and the monomer.

Describe what would be seen in each case.

with the polymer

with the monomer

[2]

(b) The diagram shows part of the structure of a condensation polymer.

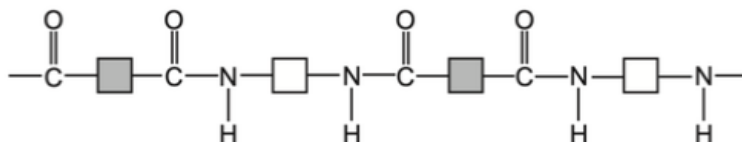

(i) What type of condensation polymer is this?
 [1]

(ii) On the diagram, draw a circle around **one** repeat unit of the polymer. [1]

(iii) Draw the structures of the **two** monomers from which the condensation polymer is made.

[2]

(c) Hydrolysis of a polymer gave a compound with the following composition by mass: C, 34.61%; H, 3.85%; O, 61.54%.

(i) Calculate the empirical formula of the compound.

empirical formula = [3]

(ii) What additional information is needed to calculate the molecular formula of the compound?

.....

..... [1]

39. The alkenes and alkanes are both examples of homologous series which are hydrocarbons.

(a) What is meant by the term *hydrocarbon*?

.....
..... [2]

(b) Give **three** characteristics of an homologous series.

1
2
3 [3]

(c) Name and draw the structure of the second member of the alkene homologous series.
Show all of the atoms and all of the bonds.

name
structure

[2]

(d) Alcohols can be made from alkenes.

Name the reagent and conditions needed to convert an alkene into an alcohol.

.....
..... [2]

(e) The alcohol butanol, $\text{CH}_3\text{CH}_2\text{CH}_2\text{CH}_2\text{OH}$, can be converted into a carboxylic acid with four carbon atoms.

(i) Name the carboxylic acid formed from butanol and draw its structure. Show all of the atoms and all of the bonds.

name

structure

[2]

(ii) Ethanoic acid can be formed from ethanol by fermentation. It can also be formed by the addition of a suitable chemical reagent.

Name the reagent needed to convert ethanol into ethanoic acid.

..... [2]

(iii) State the type of chemical change which occurs when ethanol is converted into ethanoic acid.

..... [1]

(f) Describe how a student could prepare the ester methyl ethanoate in a school laboratory. In your description give

- the names of the **two** starting organic chemicals,
- the essential reaction conditions needed,
- a chemical equation for the reaction.

.....
.....
.....
.....
.....
.....
.....
.....
..... [5]

40. (a) An homologous series is a 'family' of organic compounds whose names have the same ending.

(i) Name the homologous series for which the names of the organic compounds end in *-ene* and *-oic acid*.

-ene [1]

-oic acid [1]

(ii) State **two** characteristics of an homologous series.

.....
..... [2]

(b) Propan-1-ol is a member of the homologous series of alcohols. It reacts in the same way as ethanol with acidified potassium manganate(VII) and with carboxylic acids.

Name the **type** of compound that is formed when propan-1-ol is heated with acidified potassium manganate(VII),
ethanoic acid and a suitable catalyst. [2]

(c) The structure of prop-2-enoic (acrylic) acid is shown.

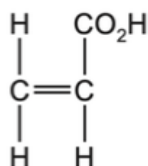

(i) What would you see if prop-2-enoic acid were added to aqueous bromine,
a solution of sodium carbonate. [2]

(ii) Prop-2-enoic acid can be polymerised to form poly(acrylic acid).

Suggest the type of polymerisation that occurs and draw **one** repeat unit of the polymer.
type of polymerisation
repeat unit

41. Cyclopropane is a colourless gas.
Cyclopropane reacts with bromine at room temperature. The chemical equation for the reaction is shown.

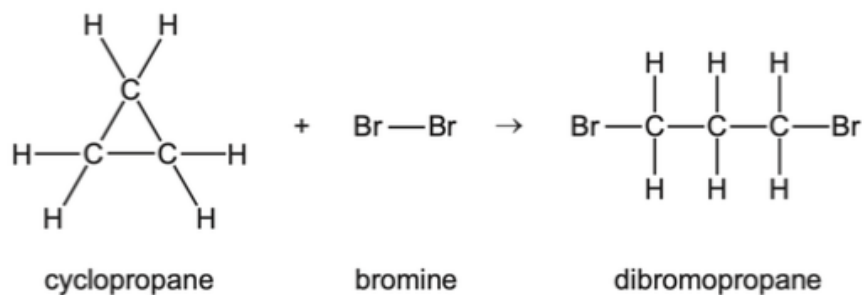

- (a) (i) What is the empirical formula of cyclopropane?

..... [1]

- (ii) What colour change, if any, would you see when cyclopropane is bubbled into aqueous bromine?

initial colour

final colour

[2]

42. The formula C_4H_{10} represents two structural isomers, **A** and **B**.

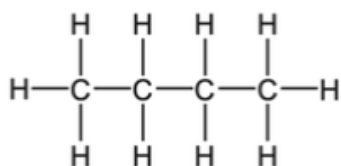

A

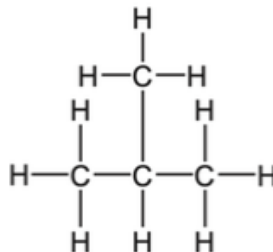

B

(i) Name isomer **A**.

..... [1]

(ii) What is meant by the term *structural isomers*?

.....

.....

..... [2]

(iii) Isomer **B** reacts with chlorine in a substitution reaction.

Give the conditions required for the reaction to occur and draw the structures of **two** possible products, **one** of which is organic and **one** of which is **not** organic.

conditions

structures of products

43. (a) Ethanol, C₂H₅OH, can be made by fermentation.

(i) Complete the chemical equation for the formation of ethanol by fermentation.



[2]

(ii) State **two** conditions required for fermentation.

1

2

[2]

(b) Ethanol can also be made by the catalytic hydration of ethene. The equation for the reaction is shown.

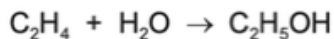

(i) Name a suitable catalyst for this reaction.

..... [1]

(ii) Calculate the maximum mass of ethanol that can be made from 56 g of ethene.

maximum mass of ethanol = g [2]

(c) Ethanol can be oxidised to form ethanoic acid.

(i) Name a suitable oxidising agent for this reaction.

..... [1]

(ii) A molecule of ethanoic acid has the structure shown.

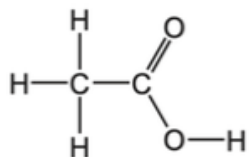

Complete the dot-and-cross diagram to show the electron arrangement in ethanoic acid. Show outer shell electrons only.

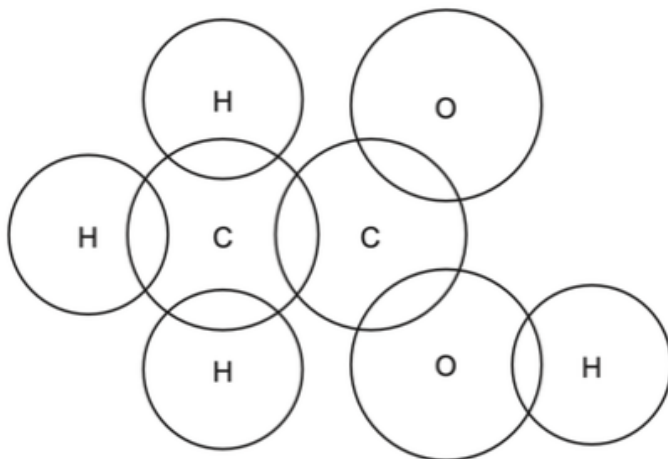

[3]

(d) Ethanoic acid is a weak acid.

(i) When referring to an acid, what is meant by the term *weak*?

.....
..... [1]

(ii) Describe how you could show that ethanoic acid is a weaker acid than hydrochloric acid.

.....
.....
.....
..... [3]

(e) Carboxylic acids react with alcohols to make esters.

The structure of an ester is shown.

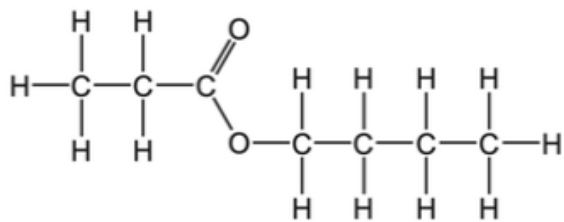

Draw the structures of the carboxylic acid and alcohol from which this ester can be made.
Give the names of the carboxylic acid and alcohol.

structure of the carboxylic acid

name of the carboxylic acid

structure of the alcohol

name of the alcohol

[4]

44. (a) Alkanes and alkenes are two homologous series of hydrocarbons.

(i) What is meant by the term *hydrocarbon*?

..... [1]

(ii) What is the general formula of the homologous series of

alkanes,

alkenes?

[2]

(iii) Other than having a general formula, state **two** characteristics of a homologous series.

1

2

[2]

(iv) The structure of an alkene molecule with the molecular formula C_4H_8 is shown.

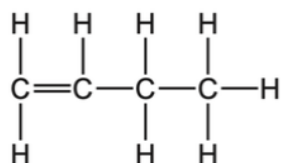

Draw the structure of a different alkene molecule with the molecular formula C_4H_8 . Show all of the atoms and all of the bonds.

[1]

(v) What term describes molecules with the same molecular formula but different structural formulae?

..... [1]

45. (a) Carbon and silicon are elements in Group IV of the Periodic Table.
Carbon dioxide from the air moves into green plants and is converted into carbohydrates.

(i) Name the process by which carbon dioxide molecules move through the air into green plants.

..... [1]

(ii) Explain why silicon(IV) oxide **cannot** move through the air in the same way that carbon dioxide can.

..... [1]

(iii) Name the process by which carbon dioxide is converted into glucose, $C_6H_{12}O_6$, in green plants. Give **two** conditions required for this process to occur. Write a chemical equation for the reaction which occurs.

name of process

condition 1

condition 2

chemical equation

[5]

(b) Starch is a natural polymer made from glucose.

(i) What type of polymerisation occurs when glucose is converted into starch?

..... [1]

(ii) What type of reaction occurs when starch is converted into glucose?

..... [1]

(iii) Starch can be represented as shown.



Complete the diagram below to represent the structure of the glucose monomer.



[1]